

# P4C-XDP: Programming the Linux Kernel Forwarding Plane using P4

William Tu, VMware NSBU  
Mihai Budiu, VMware Research  
{mbudiu,tuc}@vmware.com

June 5, 2018  
P4 Workshop

# What is eBPF / XDP ?

- A virtual machine running in Linux kernel
  - A way to write a **restricted C** program and runs in Linux kernel
  - A set of **hook points** inside kernel to invoke/run the BPF program
- Benefits
  - Extensible
  - Safe
  - Fast

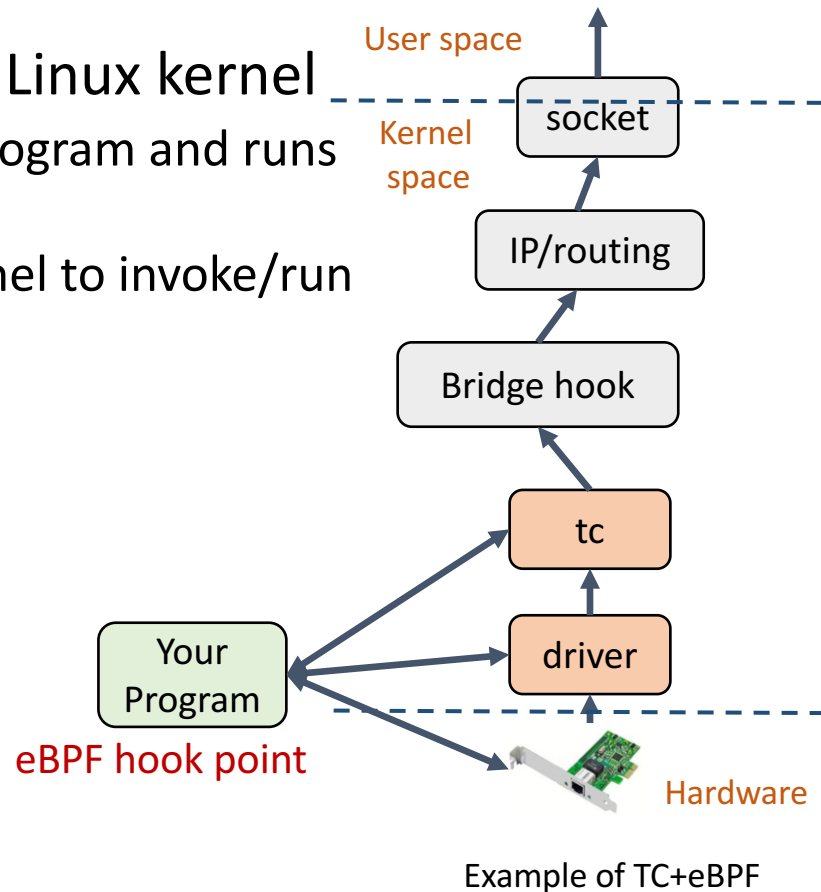

# XDP: eXpress Data Path

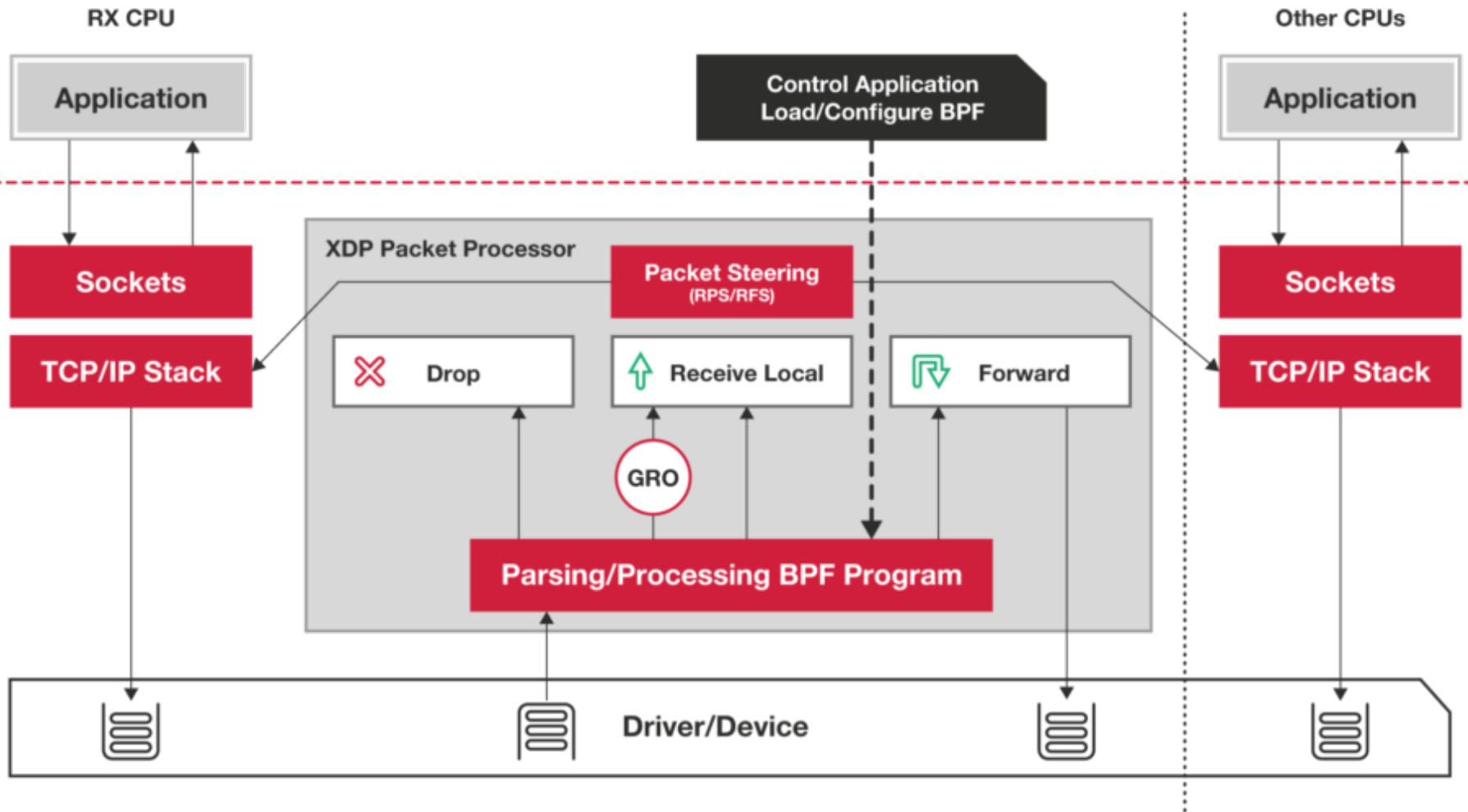

<https://www.iovisor.org/technology/xdp>

# P4<sub>16</sub> -> C -> eBPF

- p4c-xdp: back-end for the P4<sub>16</sub> reference compiler
- Generate stylized C
  - Filtering, forwarding, encapsulation
  - No loops, all data on stack
  - eBPF tables for control/data-plane communication
  - LLVM can generate eBPF bytecode

# P4<sub>16</sub> Generic Data Plane Model

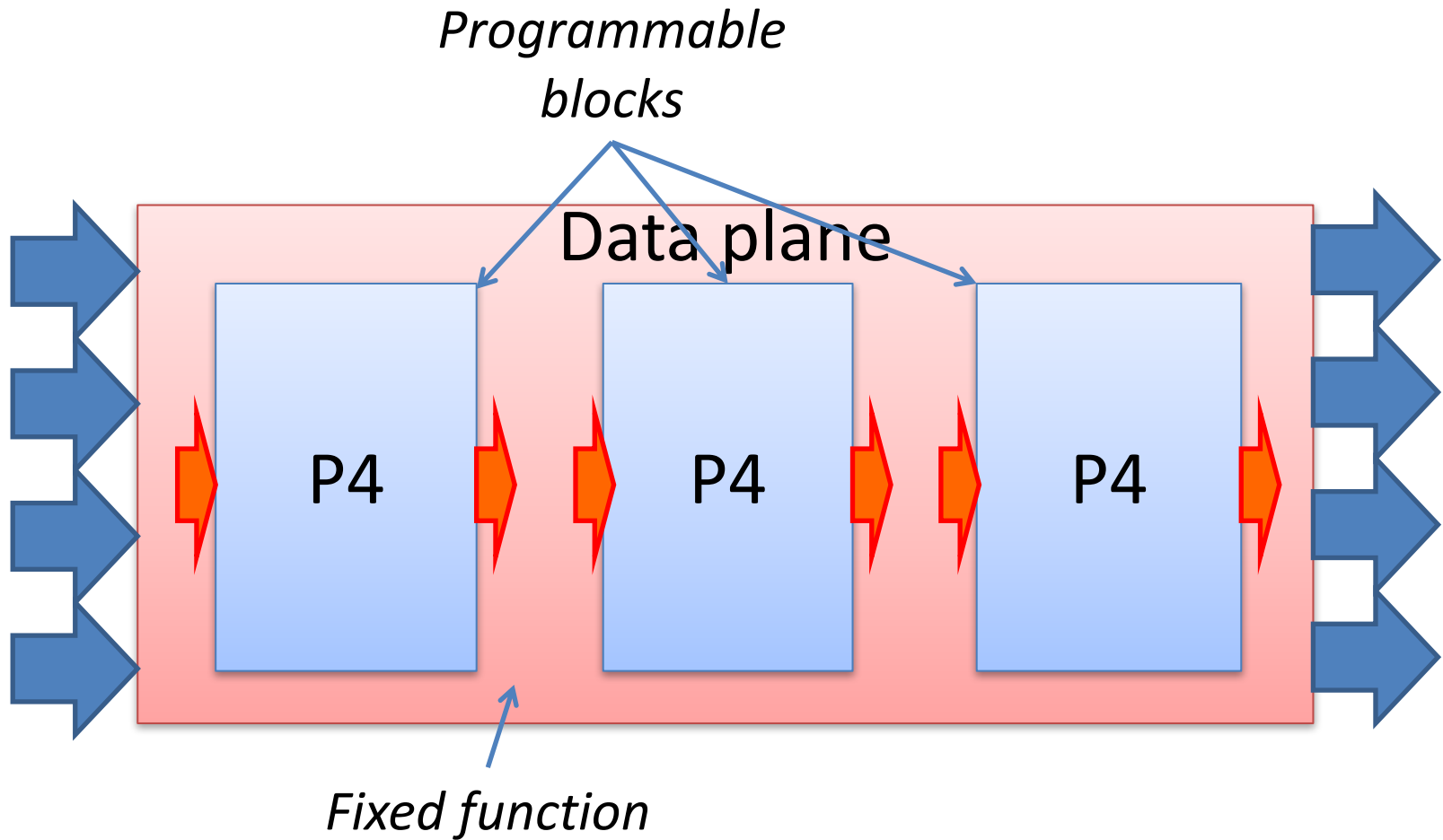

# The XDP Switching Model

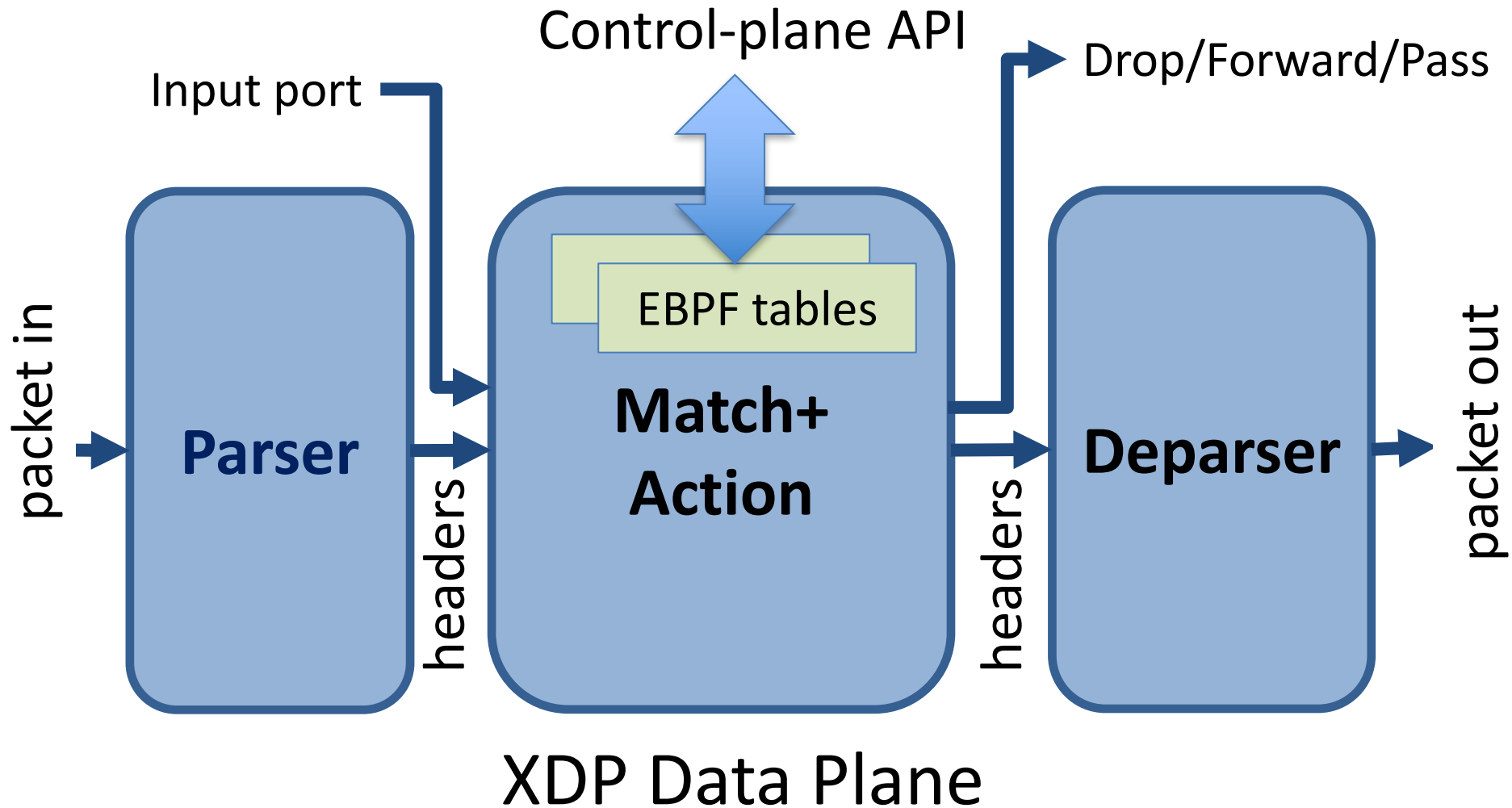

# Flow

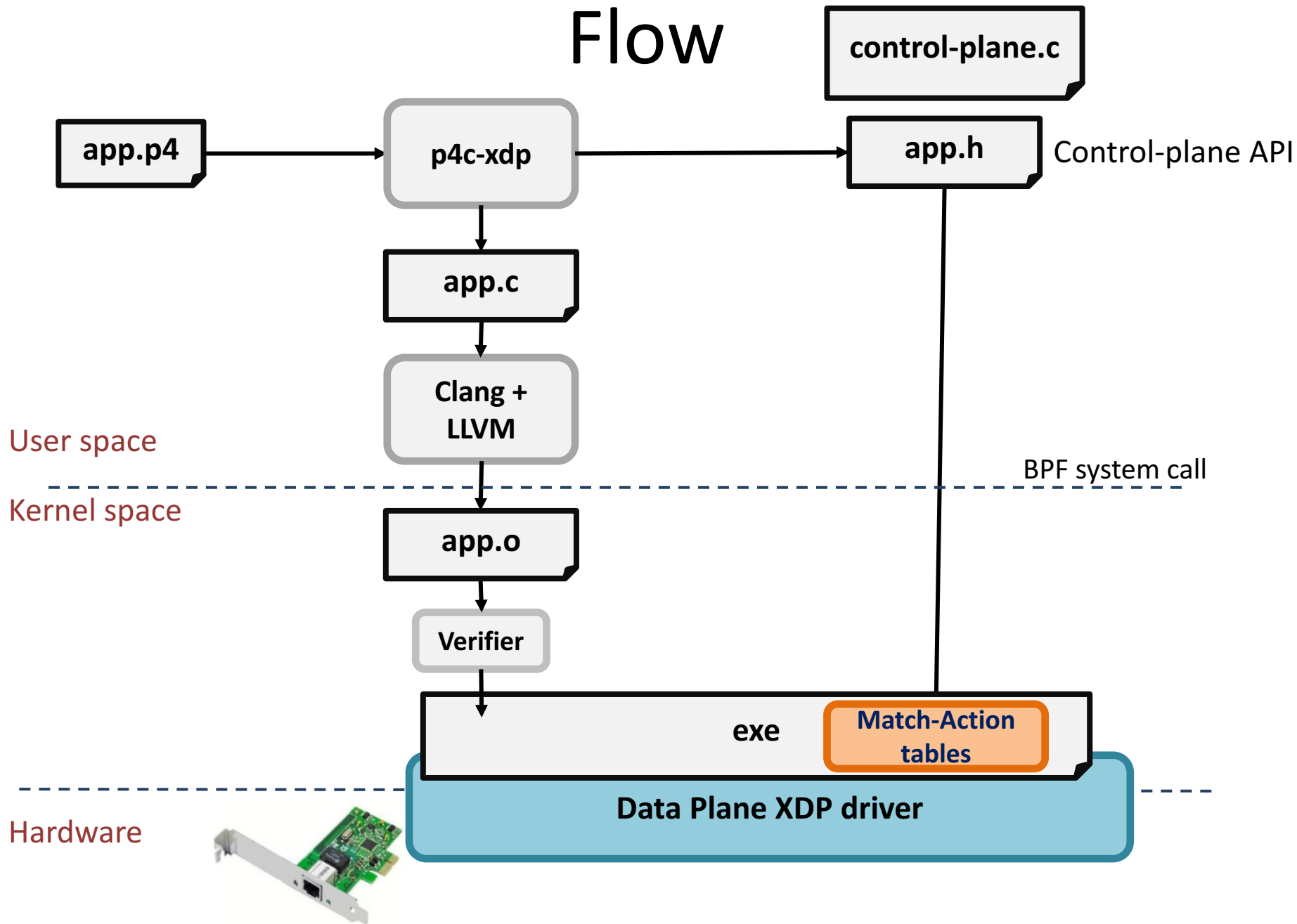

# Simple Example

- Parse Ethernet and IPv4 header
- Lookup a table using Ethernet's destination as key
- Based on Ethernet's destination address, execute two actions:
  - Drop the packet (XDP\_DROP)
  - Pass the packet to network stack (XDP\_PASS)





# Protocol Header Definition

```
header Ethernet {
    bit<48> source;
    bit<48> destination;
    bit<16> protocol;
}
header IPv4{
    bit<4> version;
    bit<4> ihl;
    bit<8> diffserv;
    ...
}
```

```
struct Headers {
    Ethernet ethernet;
    IPv4    ipv4;
}
```

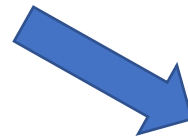

```
xdp.h
struct Ethernet{
    u8 source[6];
    u8 destination[6];
    u16 protocol;
    u8 ebpf_valid;
}
```

C struct + valid bit

# P4 Protocol Parser

```
parser Parser(packet_in packet,  
              out Headers hd) {
```

Code Block

```
  state start {
```

```
    packet.extract(hd.ethernet);
```

Direct Pkt Access

Switch-case

```
    transition select(hd.ethernet.protocol) {
```

```
      16w0x800: parse_ipv4;
```

```
      default: accept;
```

goto

```
    }
```

```
  }
```

Code Block

```
  state parse_ipv4 {
```

```
    packet.extract(hd.ipv4);
```

Direct Pkt Access

```
    transition accept;
```

```
  }
```

```
}
```

# P4: Table Match and Action

```
control Ingress (inout Headers hdr,  
                in xdp_input xin, out xdp_output xout) {  
    action Drop_action() {  
        xout.output_action = xdp_action.XDP_DROP; }  
    action Fallback_action() {  
        xout.output_action = xdp_action.XDP_PASS; }  
  
    table mactable {  
        key = {hdr.ethernet.destination : exact; }  
        actions = {  
            Fallback_action;  
            Drop_action;  
        }  
        implementation = hash_table(64);  
    }
```

Two action types

BPF HashMap

Key size of 6 byte

Value with enum type + parameter

# XDP C code: xdp1.c

```
SEC("prog")
int ebf_filter(struct xdp_md *skb) {
    struct Headers hd = {};

    ...
    /* parser */
    if (end < start + header_size)
        goto reject;
    hd.ethernet.destination[0] = load_byte(...);
    ...
    /* match+action*/
    value = bpf_map_lookup_elem(key);
    switch(value->action) {
        case Drop_action:
            ...
    /* deparser */
    xdp_adjust_head();
    // update packet header
    return xout.xdp_output;
}
```

# Generate Header for Control Plane

**Generate:** xpd1.h

```
struct mactable_key {
    u8 field0[6];
}

enum mactable_actions {
    Fallback_action,
    Drop_action,
}

struct mactable_value {
    enum mactable_actions action;
    union {
        struct {
        } Fallback_action;
        struct {
        } Drop_action;
    } u;
}
```

**User provide:** user\_xpd1.c

```
#include "xpd1.h"

int main () {
    int fd = bpf_obj_get(MAP_PATH);
    ...
    struct mactable_key key;
    memcpy(key.field0, MACADDR, 6);
    struct mactable_value value;
    value.action = Fallback_action;
    // Add a new entry to the table
    bpf_update_elem(fd, &key, &value, BPF_ANY);
}
```

# Setup and Installation

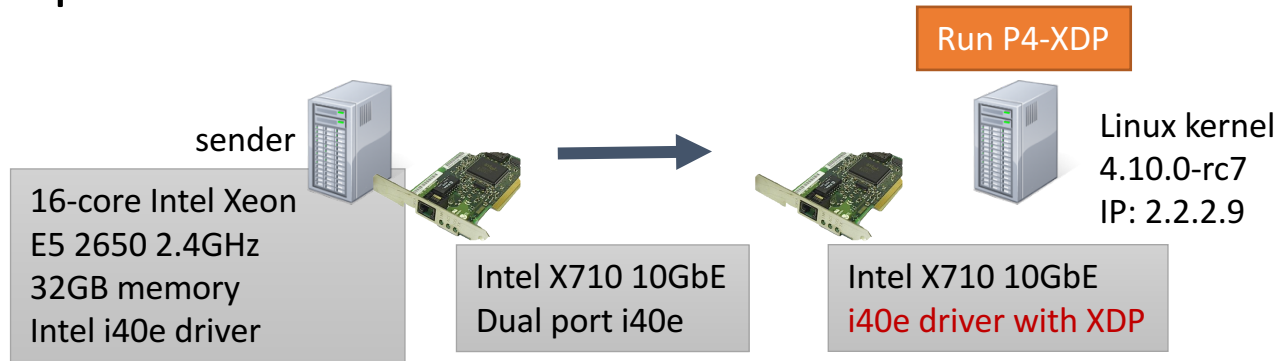

- Source code at Github (Apache License)
  - <https://github.com/vmware/p4c-xdp>
  - Vagrant box / docker image available
- Dependencies:
  - P4 2016: <https://github.com/p4lang/p4c>
  - Linux >= 4.12: <http://www.kernel.org/>
  - iproute2 >= 4.8.0: <https://www.kernel.org/pub/linux/utils/net/iproute2/>
  - clang+LLVM >=3.7.1: <http://llvm.org/releases>
- P4C-XDP binary
  - `#!/p4c-xdp --target xdp -o <output_file> <input p4>`

# Demo1: Swap Ethernet (xdp11.p4)

- Swap Ethernet source and destination
- Send to the receiving interface (return **XDP\_TX**)

```
bit<48> tmp;
apply {
    if (hd.ipv4.isValid())
    {
        tmp = hd.ethernet.destination;
        hd.ethernet.destination = hd.ethernet.source;
        hd.ethernet.source = tmp;
    }
}
```

<https://youtu.be/On7hEJ6bPVU>

<https://github.com/vmware/p4c-xdp/blob/master/tests/xdp11.p4>

# Thank You

Questions?

<https://github.com/vmware/p4c-xdp>



## Demo2: ping4/6 and stats (xdp12.p4)

- Parse IPv4/IPv6 ping
- Drop ipv6 ping, and return **XDP\_DROP**
- Enable Control plane
- Update ipv4 statistics, and return **XDP\_PASS**

<https://youtu.be/vlp1MzWVOc8>

# Deparser: Update the Packet

```
control Deparser(in Headers hdrs,  
                packet_out packet) {  
    apply {  
        packet.emit(hdrs.ethernet);  
        packet.emit(hdrs.vlan_tag);  
        packet.emit(hdrs.ipv4);  
    }  
}
```

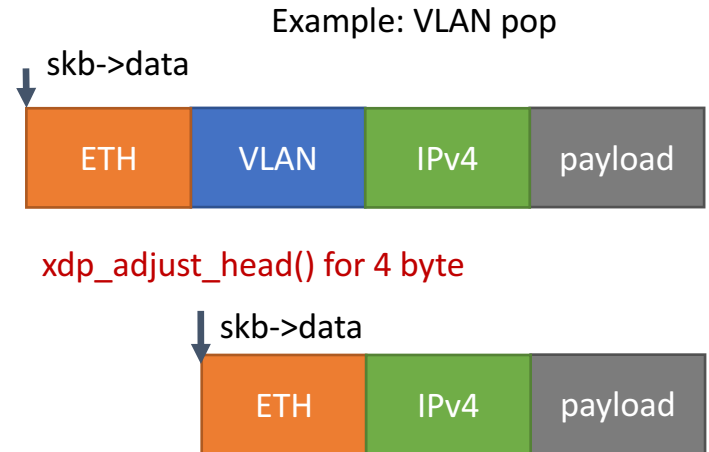

The payload remains in the same memory

- Users can push/pop headers by emitting more or skipping emit
  - Ex: vlan push/pop by add/remove  
`packet.emit(hdrs.vlan_tag);`
  - Need to adjust `skb->data` by adding `xdp_adjust_head` helper

# xdp\_model.p4

```
enum xdp_action {
    XDP_ABORTED, // some fatal error occurred during processing;
    XDP_DROP,    // packet should be dropped
    XDP_PASS,    // packet should be passed to the Linux kernel
    XDP_TX       // packet resent out on the same interface
}

struct xdp_input {
    bit<32> input_port;
}

struct xdp_output {
    xdp_action output_action;
    bit<32> output_port; // output port for packet
}

parser xdp_parse<H>(packet_in packet, out H headers);
control xdp_switch<H>(inout H hdrs, in xdp_input i, out xdp_output o);
control xdp_deparse<H>(in H headers, packet_out packet);
```

# P4-XDP: xdp1.c

```
SEC("prog")
```

```
int ebpf_filter(struct xdp_md *skb) {
    struct Headers hd = {};
    ...
    /* parser */
    if (end < start + header_size)
        goto reject;
    hd.ethernet.destination[0] = load_byte(...);
    ...
    /* match+action*/
    value = bpf_map_lookup_elem(key);
    switch(value->action) {
        case Drop_action:
            ...
    }
    /* deparser */
    xdp_adjust_head();
    // update packet header
    return xout.xdp_output;
}
```

- Parser:
  - Check packet access boundary.
  - Walk through the protocol graph.
  - Save in “struct Headers hd.”
- Match+Action:
  - Extract key from struct Headers
  - Lookup BPF hash map
  - Execute the corresponding action
- Deparser
  - Convert headers back into a byte stream.
  - Only valid headers are emitted.